

Preface

The objective of this document is to provide technical and operational specifications and requirements for the cabling of a range of premises and buildings to meet AUSTAR standards. The intention is to ensure every one has a very clear understanding of what is required and what standards must be met. In all cases reference must be made to the Australian Standard AS/NZ 1367; 2007 4th edition which includes changes in the transmission formats.

Optical
DVB-T
DVB-C
DVB-S

This edition supersedes AS/NZ 1367; 2000 and has many new updates which must be used as reference data.



Index

1	PASSIVE EQUIPMENT	6
1.1	TERMINAL FLY-LEADS	6
1.2	WALLPLATE SPECIFICATION	6
1.3	SPLITTERS AND TAPS	6
1.4	OTHER PASSIVE DEVICES	7
1.5	COAXIAL CABLE	7
1.6	COAXIAL CONNECTORS	7
1.7	TYPICAL COAX QUADSHIELD DETAIL	7
2	ACTIVE EQUIPMENT	9
2.1	ACTIVE DISTRIBUTION EQUIPMENT	9
2.2	SATELLITE I.F. AMPLIFIERS	9
2.3	FREQUENCY RANGE	9
2.4	NOMINAL IMPEDANCE	9
2.5	RETURN LOSS	9
2.6	GAIN AND SLOPE CONTROL	9
2.7	FLATNESS	9
2.8	TEST POINTS	9
2.9	NOISE FIGURE	9
2.10	NON-LINEAR DISTORTION IN BROADBAND AMPLIFIERS	10
2.11	SCREENING EFFECTIVENESS OF EQUIPMENT	10
2.12	POWER SUPPLY	10
2.13	LOW NOISE BLOCK CONVERTER (LNB)	10
2.14	MULTISWITCHES	10
2.15	END OF LINE 2 INPUT MULTISWITCH SPECIFICATION:	10
2.16	END OF LINE 3 INPUT MULTISWITCH SPECIFICATION:	11
2.17	CASCADABLE 3 INPUT MULTISWITCH SPECIFICATION	11
3	DISH SIZE CRITEREA	12
4	SATELITE IF SYSTEM PARAMETERS	13
4.1	GENERAL	13
4.2	OUTLET LEVELS: I.F. SATELLITE	13
4.3	SATELLITE LNB RECEIVE LEVELS	13
4.4	RF MUTUAL ISOLATION BETWEEN OUTLETS:	13
4.4.1	SATELLITE I.F. AMPLIFIER LEVELS	13
5	NORMAL MATV R.F. SYSTEM PARAMETERS	14
5.1	GENERAL	14
5.2	OUTLET LEVELS: RF MATV	14
5.3	RF MUTUAL ISOLATION BETWEEN OUTLETS	14
5.4	AMPLIFIER MAXIMUM OUTPUT LEVEL AND DE-RATING	14
5.5	R.F. AMPLIFIER LEVELS	14
5.6	PASSIVE DEVICE LOSSES	14
6	SYSTEM OUTLET LEVELS AND PERFORMANCE	15
6.1	DIGITAL VIDEO BROADCAST SATELLITE (DVB-S) TELEVISION CHANNELS	15
6.2	ANALOGUE AND DIGITAL VIDEO BROADCAST TERRESTRIAL (DVB-T) TELEVISION CHANNELS	15
6.3	FM RADIO	15
7	MEASURING SATELTITE QPSK SIGNAL	16
7.1	Characteristics of Ratio types measured in Digital systems (informative)	16

8	CABLING STANDARDS AND PROCEEDURES	18
8.1	SYSTEM PLAN AND DRAWINGS:	18
8.2	EXTERNAL CABLING	18
8.2.1	Segregation	18
8.2.2	Equipment Specifications	18
8.2.3	External Duct Installation	18
8.2.4	Approved Cables	18
8.2.5	Techniques	18
8.2.6	Conduit and Supports	18
8.2.7	Sharp edges	18
8.2.8	Cable housing	19
8.2.9	Fixing	19
8.2.10	Terminating tools	19
8.2.11	Underground Cable Runs	19
8.2.12	Catenary Cable Runs	19
8.2.13	Labelling of cables	19
8.3	INTERNAL CABLING	19
8.3.1	Segregation	19
8.3.2	Equipment Specifications	19
8.3.3	Approved cables	19
8.3.4	Cable selection	19
8.3.5	Support	20
8.3.6	Sharp edges	20
8.3.7	Cable housing	20
8.3.8	Fixing	20
8.3.9	Terminating tools	20
8.3.10	Labelling of cables	20
8.4	THE MDU HEADEND	20
8.4.1	Lead in Cable	20
8.4.2	Amplifiers and Passives	20
8.4.3	Housing	20
8.4.4	Ventilation	20
8.4.5	Mounting	21
8.4.6	Cable entry	21
8.4.7	Power	21
8.4.8	Earthing	21
8.5	8.5 SUB-DISTRIBUTION	21
8.5.1	Amplifiers, Multiswitches and Passives	21
8.5.2	Housing	21
8.5.3	Mounting	21
8.5.4	Cable entry	21
8.5.5	Power	21
8.6	SYSTEM OUTLETS	22
8.6.1	Equipment Specifications	22
8.6.2	Outlet plates	22
8.7	CABLE ATTENUATION AND EQUALISATION	22
8.7.1	ATTENUATION AND EQUALISATION	22
8.7.2	EQUALISATION	22
9	AUSTAR CAD DRAWING STANDARD	25
9.1	INTRODUCTION	25

9.1.1	Building outline:	25
9.1.2	Existing headend and distribution system:	25
9.1.3	Proposed headend and distribution system.	25
9.1.4	As-Built headend and distribution system.	25
9.2	DRAWING FORMATS	25
9.3	REQUIRED SMATV SYSTEM DRAWING DETAIL:	26
9.3.1	Plan Identification	26
9.3.2	Specification Text, legend or Data section	26
9.3.3	Cable Distances	26
9.3.4	Underground and Catenary cable runs	26
9.3.5	Power Insertion Devices	26
9.3.6	Amplifiers	26
9.3.7	Splitters, Taps and Multiswitches	27
9.3.8	Outlet Plates	27
9.3.9	Headend and sub-distribution points	27
9.3.10	Pedestals	27
9.3.11	Conduit locations and entry points	27
9.4	DRAFTING SYMBOLS.	28
9.5	EXAMPLE OF BUILDING OUTLINE WITH EXISTING SYSTEM	29
9.6	EXAMPLE OF BUILDING OUTLINE WITH PROPOSED SYSTEM	30
9.7	EXAMPLE OF PROPOSED MDU DESIGN DRAWING	31
9.8	EXAMPLE OF AS-BUILT CAD DRAWING	32
10	EARTHING OF A SYSTEM	33
10.1	EARTHING OVERVIEW	33
10.2	PREFERRED METHODS FOR CET AND BONDING CONDUCTOR CONNECTION	33
10.3	CONNECTION OF THE BONDING CONDUCTOR TO THE EARTHING CONDUCTOR	34
10.3.1	Connection of conductors	34
10.3.2	Installation of Amalgam Tape	34
10.3.3	Connection with Insulation Reinstated	35
10.3.4	Simplified Version of a Bonding System	35
11	FIBRE OPTICAL CONNECTORS	36
11.1	ST*/PC FIBRE OPTICAL CONNECTORS	36
11.2	SC/APC DUPLEX FIBRE OPTICAL CONNECTORS SINGLE MODE	36
11.3	INTER CONNECTING LEADS	36
11.4	FOBOT	36
11.5	CABLE TYPES	36
11.6	CABLE BENDING RADIUS	36
11.7	PIG TAILS	36
11.8	SITE SPECIFIC	37
11.9	DRIVE LEVELS	37
11.10	EQUIPMENT	37
11.11	Typical three trunk fibre diagram	38
11.11.1	Attention: Commissioning Detail	39

1 PASSIVE EQUIPMENT

Attention: All equipment used must be on the current AUSTAR Approved Parts List

1.1 TERMINAL FLY-LEADS

Terminal fly-leads are defined as those cables that connect a terminal device to a system outlet and/or those cables that connect a customer's terminal device to any device connected between the system outlet and the input to the terminal device.

Fly-leads will be comprised of RG6 Quad Shield cable.

All connectors fitted to terminal fly-leads shall comply with IEC 60169-1 and either IEC 60169-2 or, in the case of F-type connectors, IEC 60169-24. All connectors must be compression type and be on the AUSTAR approved parts list.

The return loss of terminal fly-lead when terminated with a precision termination should be ≥ 14 dB in the range 5MHz to 2050MHz.

The terminal fly-lead shall be constructed from cable having the same structural return loss as that specified under coaxial cable in this section.

The screening effectiveness of the fly-lead, measured according to IEC 60996-1 Amendment 1, should be ≥ 95 dB in the range 30MHz to 1000MHz and ≥ 85 dB in the range above 1000MHz to 2050MHz.

To minimise the chances of damage, the dielectric of the fly-lead should be continuous along its entire length in the manner specified under coaxial cable in this section.

1.2 WALLPLATE SPECIFICATION

The system outlet connectors servicing the TV interface port should comply with IEC 60169-24 and IEC 60169-1.

The maximum diameter of the male centre pin contacts used with these wall plate connectors must not exceed 1.762mm.

The return loss of any TV interface port, located on the system outlet, should be ≥ 18 dB in the range 40MHz to 2050MHz, reducing by -1.5 dB / octave, to no less than 10dB. (refer AS/NZS 1367-2007).

The screening effectiveness of the system outlet, measured according to IEC 60996-1, should be ≥ 75 dB in the range 30MHz to 1000MHz and ≥ 65 dB in the range above 1000MHz to 2050MHz.

Mains isolation is not permitted as it will disable the switching function of the multiswitch, and all systems should be earthed for Safety in accordance with AS1367.

1.3 SPLITTERS AND TAPS

The return loss for all ports located on taps and splitters shall be ≥ 14 dB in the range 5MHz to 2050MHz.

For all taps, the peak-to-peak narrowband flatness from input to output and, input to any customer tap port, shall be ± 0.2 dB for any 0.5MHz segment and ± 0.5 dB for any 7MHz segment.

The isolation between the output ports for a splitter shall be ≥ 18 dB in the range 5MHz to 862MHz and ≥ 14 dB in the range 40MHz to 2050MHz.

In the case of splitters with unequal output division, the above requirements for isolation shall be increased by the difference in attenuation between the output ports.

The RF mutual isolation between output ports for directional couplers and distribution taps shall be ≥ 27 dB within the band 5 MHz to 862 MHz and ≥ 17 dB within the band 950 MHz to 2050 MHz. These values shall be published.

The screening effectiveness of any splitter or tap, measured according to IEC 60996-1 shall be ≥ 75 dB in the range 30MHz to 1000MHz and ≥ 65 dB in the range above 1000MHz to 2050MHz.

In both I.F and RF distribution systems, designs should aim to limit cascaded taps to 3 or less.

In RF MATV distribution systems, outlet plates should always connect to a tap, not a splitter: ie: Splitters should always feed downstream into taps where taps then connect to the outlet plate, to maximise isolation between outlets.

Trunks should always be terminated with a tap as the last trunk line passive, and the tap through port must be terminated with a 75 ohm terminator capable of handling 18v. In simple star wired 4,6 and 8 outlet systems, a low value side-loss tap should be used in preference to a splitter.

1.4 OTHER PASSIVE DEVICES

These devices include transfer points, power inserters / injectors, cable splices, galvanic isolators, terminating resistors, filters and equalisers.

The return loss on all ports of these devices should be ≥ 14 dB in the range 5MHz to 2050MHz. The peak-to-peak narrowband flatness from input to output port for one and two port devices should be ± 0.2 dB for any 0.5MHz and ± 0.5 dB for any 7MHz segment.

The screening effectiveness of these devices, measured according to IEC 60996-1, should be ≥ 75 dB in the range 30MHz to 1000MHz and ≥ 65 dB in the range above 1000MHz to 2050MHz.

1.5 COAXIAL CABLE

All trunk and drop cables must be quad shielded cable. Tri shielded and dual shielded cable are **not** acceptable.

To minimise the chance of damage during installation and corrosion after installation, flexible cables, for example, RG6 and RG11, must have a continuous dielectric such that the centre solid conductor is in full contact with the dielectric and homogenous to the shield, along the entire length of the cable.

Cables that comply with this standard include those constructed with solid, foam or cellularised-polymer dielectrics as long as they comply with all parts of this section where appropriate.

Flexible cables constructed without this characteristic, such as air-spaced or semi-air spaced cables, or cables with a multi-strand centre conductor do **not** comply with this specification and are not to be used. Refer AUSTAR APL.

The use of backbone hardline cables constructed with a sealed cell dielectric, or equivalent, that prevents moisture entry is permitted.

All cables installed underground must be of the flooded (silicon infused) type and installed in heavy duty (HD) conduit designed for underground burial, usually orange in colour, unless using hardline cable specifically designed for direct burial.

The screening effectiveness of super trunk feeders, trunk feeders and branch feeders, measured according to IEC 60996-1 Amendment 1, should be ≥ 95 dB in the range 30MHz to 1000MHz and ≥ 85 dB in the range above 1000MHz to 2050MHz.

The screening effectiveness of customer's drop feeders, measured according to IEC 60996-1 Amendment 1, should be ≥ 95 dB in the range 30MHz to 1000MHz and ≥ 85 dB in the range above 1000MHz to 2050MHz.

The structural return loss for all cables, including terminal fly-leads, should be not less than 26dB.

Note: Refer to the AUSTAR Approved Parts List for further approved cable types and AS/NZ 1367:2007

1.6 COAXIAL CONNECTORS

Only compression F-type connectors are to be used.

The connectors specified above should comply with IEC 60169-24. The connectors used in conjunction with backbone hardline cables should be pin type in construction. The use of feed through connectors on these cables does not comply with this Specification.

The return loss of the connectors specified above should be ≥ 20 dB in the range 5MHz to 2050MHz, measured in accordance with IEC 60169-1.

The screening effectiveness of the connectors specified above measured according to IEC 60996-1., should be ≥ 75 dB in the range 30MHz to 1000MHz and ≥ 65 dB in the range above 1000MHz to 2050MHz.

It is a requirement of the Specification that in addition to the specifications mentioned above, all connectors used to terminate cables should meet those specifications published by the applicable cable manufacturer.

1.7 TYPICAL COAX QUADSHIELD DETAIL

A. Centre Conductor Copper-clad steel 22% minimum conductivity.

- B. Dielectric Closed cell, high velocity precision matrix foamed polyethylene which provides optimum dielectric hardness. The foam is bonded to the centre conductor with a clean stripping, proprietary moisture-blocking polymer.
- C. First Outer Conductor Sealed aluminium-polypropylene-aluminium (APA) laminated tape, in conjunction with the second shield, provides an additional shield for improved signal isolation.
- D. Second Outer Conductor Standard coverage aluminium alloy wire braids improve shielding ability and provide additional mechanical strength.
- E. Third Outer Conductor unsealed aluminium-polypropylene-aluminium (APA) laminated tape, in conjunction with the second shield provides an additional shield for improved signal isolation.
- F. Fourth Outer Conductor Aluminium alloy wire braids, in conjunction with the first braids, sandwiches the second tape assuring good metallic contact in the overlap of the tape.
- G. Jacket Protective PVC applied over the braid to environmentally seal the construction.

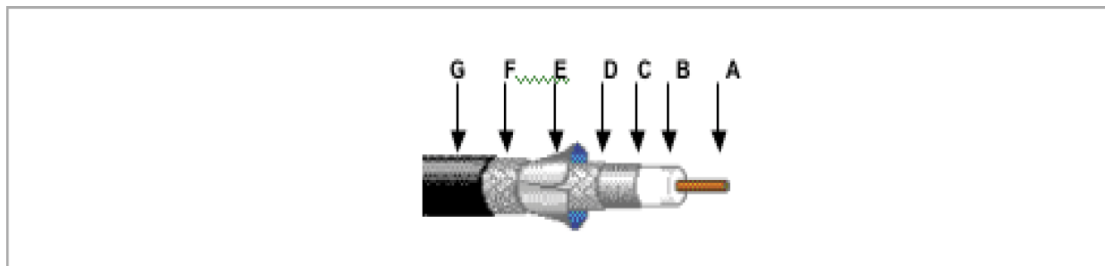

AUSTAR®

2 ACTIVE EQUIPMENT

Attention: All equipment used must be on the current AUSTAR Approved Parts List

2.1 ACTIVE DISTRIBUTION EQUIPMENT

This specification is applicable to all coaxial limited bandwidth and broadband amplifiers used in cable distribution systems in the frequency range 5MHz to 2050MHz.

Amplifiers that comply with the specifications may be exclusively forward path or reverse path amplifiers or possess both forward and reverse path capability.

All amplifiers must incorporate F Type input and output ports.

2.2 SATELLITE I.F. AMPLIFIERS

These cover separate Launch and Line amplifiers or line amplifiers that are capable of combining FTA services where applicable as well as separate vertical and horizontal services from the satellite.

Where signals are to be distributed throughout a dual polarity distribution system the amplifier head end system must have two or three separate outputs to allow separation of Free to Air, vertical and horizontal I.F. services.

Where required, a line amplifier should have built in line thru-powering option to provide voltage to the LNBF and or next line amplifier / multiswitch where required. If the amplifier does not have line powering options power inserters and dual 240v GPO should be allowed for with the correct polarity voltage and current for the application on hand.

2.3 FREQUENCY RANGE

The frequency range or ranges, over which the equipment is specified, shall be published in the CAD specification.

2.4 NOMINAL IMPEDANCE

The nominal impedance of all amplifier ports including test points should be 75 ohms. All measurements are to be referred to this impedance.

2.5 RETURN LOSS

The return loss specification of all input and output ports of an amplifier should be achieved under all specified conditions of automatic and manual gain and slope controls and with any combination of plug-in equalisers and attenuators fitted.

The return loss of all ports of any broadband or limited bandwidth amplifier should be $\geq 18\text{dB}$ in the range 5MHz to 2050MHz.

2.6 GAIN AND SLOPE CONTROL

The variable gain control may be either plug-in pad or potentiometer. Typically 0 – 20dB.

The variable equaliser slope control may be either plug-in pad or potentiometer. Typically 0 – 12dB.

2.7 FLATNESS

The flatness specifications should be achieved in all specified conditions of automatic gain control, manual gain control with any combination of plug-in equalisers and attenuators specified for use with the device.

The flatness of the amplitude frequency response from the input to the output ports shall be published. Slope is assumed to be eliminated either by calculation or by cable.

The peak-to-peak narrowband flatness from the input port to any output port should be $\pm 0.2\text{dB}$ for any 0.5MHz segment and $\pm 0.5\text{dB}$ for any 7MHz segment.

2.8 TEST POINTS

Test points should have an impedance of 75 ohms. The return loss should correspond to that specified in Return Loss above.

2.9 NOISE FIGURE

The maximum noise figure over the specified frequency range should be $\geq 9\text{dB}$.

2.10 NON-LINEAR DISTORTION IN BROADBAND AMPLIFIERS

A broadband amplifier in this context is defined as one having a continuous bandwidth greater than 10 AM television channels.

Composite Triple Beat (CTB). The worst-case value over all channels should be 60dB signal to CTB ratio.

Composite Second Order (CSO). The worst-case value over all channels should be 63dB signal to CSO ratio.

Composite Crossmodulation (CCM). The worst-case value over all channels should be 63dB signal to CCM ratio.

The above figures assume a channel loading of 77CHs and an output level of 100dBuV.

(This figure may be derated by 5dB when the amplifier is intended to drive a small number of outlets, typically up to 24.)

2.11 SCREENING EFFECTIVENESS OF EQUIPMENT

The screening effectiveness of all active distribution equipment including multiswitches measured according to IEC 728 should be ≥ 75 dB in the range 30MHz to 1000 MHz and be ≥ 65 dB in the range above 1000MHz to 2050MHz.

2.12 POWER SUPPLY

The power supplies of all active distribution equipment should be capable of continuous operation and rated to meet local AC mains specifications and have a 'Certificate of Suitability' from the relevant Australian energy authority (except where the unit is a line powered device).

2.13 LOW NOISE BLOCK CONVERTER (LNB)

All new MDU and AUSTAR For Business installations must use AUSTAR Approved LNB's with a local oscillator frequency (L.O.) of 10.7 GHz. All multiswitched installations must use a dual and or 4 output 10.7 L.O. LNB. (LNB's with a L.O. of 11.3 GHz are not permitted in any new AUSTAR installations).

2.14 MULTISWITCHES

Where a stand alone dual polarity satellite I.F system is installed the device must have two input ports, and the correct number of output or switching ports depending on the application at hand.

If a cascaded (looped) multiswitch system is used the device should have two input ports, two looped or through ports with the correct number of output ports to suit the application at hand. Where an integrated FTA plus dual polarity satellite I.F system is used the device must have three input ports, and the correct number of output ports depending on the application at hand. This is explained in more detail in system design samples.

If a cascaded integrated FTA plus dual polarity multiswitch system is used the device must have three input ports, three looped or through ports with the correct number of output ports to suit the application at hand.

2.15 END OF LINE 2 INPUT MULTISWITCH SPECIFICATION:

End of Line 2 input IF only Multiswitches should comply with the following specification as a minimum:

Separate Vertical and Horizontal IF inputs

Subscriber connection ports 4,6,8 or 12

Frequency range satellite 950-2050 MHz

Return loss all ports > 10 dB

Output port loss / gain to suit application

Switching isolation > 25 dB

Isolation Port to Port > 25 dB

Current consumption < 75 mA

Noise figure active devices < 7 dB

Output level capability 85dBuV minimum (3rd order interference products 35dBIM 2-carrier measuring method according to DIN EN 50083-3).

2.16 END OF LINE 3 INPUT MULTISWITCH SPECIFICATION:

End of line 3 input Multiswitches should comply with the following specification as a minimum:

Separate Vertical and Horizontal IF inputs.

1 separate FTA input.

Subscriber connection ports 4,6 or 8. (non mains powered units).

Subscriber connection ports 4,6,8,12,16 (mains powered units).

Frequency range FTA 5-862 MHz.

Frequency range satellite 950-2050 MHz.

Return loss all ports > 10dB.

Satellite output loss / gain to suit application.

FTA passive loss to suit application (Passive FTA operation only will negate the need for mains power).

FTA loss / gain to suit application (line powering or mains powering may be required for multiswitches with FTA gain).

Isolation Horizontal / Vertical minimum >25dB.

Isolation Port to Port > 27dB FTA, >25dB satellite.

Switching isolation 25 dB.

Rejection FTA / satellite 24dB.

Rejection satellite to FTA 45dB.

Current consumption < 110 mA (non mains powering).

Satellite noise figure for multiswitches < 7dB.

Output level capability 85dBuV minimum (3rd order interference products 35dBIM 2-carrier measuring method according to DIN EN 50083-3).

2.17 CASCADABLE 3 INPUT MULTISWITCH SPECIFICATION

Cascading 3 input Multiswitch should comply with the following specification as a minimum:

Separate Vertical and Horizontal inputs.

1 FTA input.

Subscriber connection ports 4,6.

Frequency range Free to Air (FTA) 5-862 MHz.

Frequency range satellite 950-2050 MHz.

Return loss all ports > 10dB.

Satellite output loss / gain to suit application.

FTA loss / gain to suit application (line powering or mains powering may be required).

Isolation trunk to trunk (FTA) >45dB, satellite >33dB.

Isolation Horizontal / Vertical minimum >25dB.

Isolation Port to Port > 27dB FTA, >25 dB satellite.

Switching isolation 25 dB.

Rejection FTA / satellite 24dB.

Rejection satellite to FTA 45dB.

Current consumption < 35 mA from receiver.

DC through path per trunkline 1.5A.

Satellite noise figure active devices < 7dB.

Output level capability 85dBuV minimum (3rd order interference products 35dBIM 2-carrier measuring method according to DIN EN 50083-3).

3 DISH SIZE CRITEREA

The satellite dish size required to provide adequate signal strength, Modulation Error Ratio (MER) and Carrier to Noise ratio (C.N.R.) will vary significantly across Australia, and so a site survey is required to determine the dish size requirement in accordance with the following minimum C.N.R. and MER specification.

Regardless of installation type, the goal for adequate dish size selection is to provide a minimum C.N.R. of 13 dBuV at the AUSTAR decoder input. Generally a 1dB added margin is required at the dish to achieve this result as follows:

AUSTAR INSTALLATION	TYPE REQUIRED DISH SIZE
Simple MDU with no I.F. amplification before the multiswitch	Min 65 cm or larger to achieve min 15 dB CNR and 13 MER at the LNB in clear sky across all AUSTAR transponders
MDU, Bulk Headend or PVA System with 1 x I.F. amplifier before the multiswitch	MIN 85 cm or larger to achieve min 16 dB CNR and 14 MER at the LNB in clear sky across all AUSTAR transponders.
MDU, Bulk Headend or PVA System with 2 x I.F. amplifiers before the multiswitch	MIN 85 cm or larger to achieve min 16 dB CNR and 14 MER at the LNB in clear sky across all AUSTAR transponders
Large residential MDU/MRE QPSK HFC system with 2 x I.F. amplifiers before the multiswitch	MIN 85 cm up to 1.2 m to achieve min 17 dB CNR and 15 MER at the LNB in clear sky across all AUSTAR transponders
Multiswitched Commercial Bulk headend and PVA installation without line amplification	MIN 85 cm up to 1.2 m to achieve min 15 dB CNR and 13 MER in clear sky across all AUSTAR transponders

These dish sizes have been nominated to provide higher Carrier to Noise performance at the Headend to compensate for C.N.R. degradation from line or launch amplifiers, multiswitches and multiple passive devices. This provides increased head room and reduces the effects of rain fade for the subscriber. Minimum required Carrier to Noise Ratios (CNR) specified are for clear sky conditions across all transponder streams.

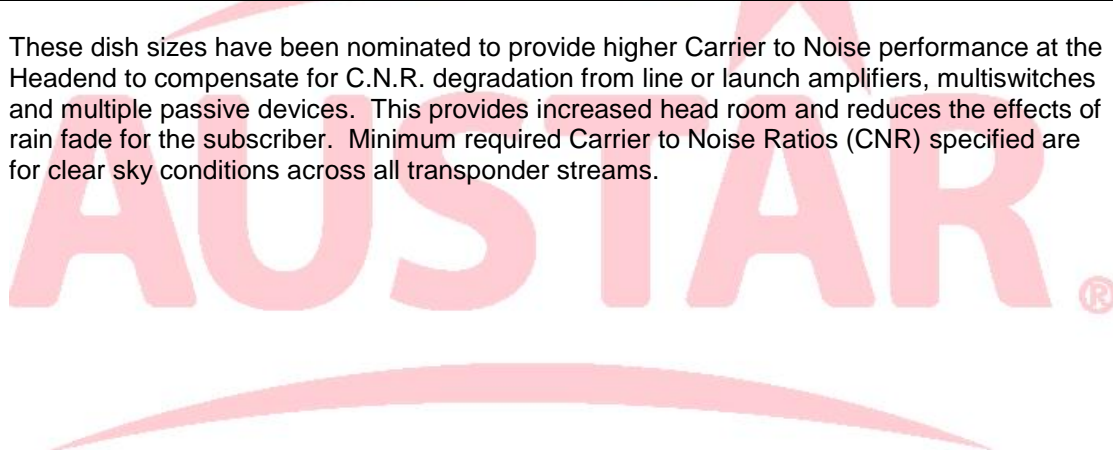

4 SATELITE IF SYSTEM PARAMETERS

4.1 GENERAL

LNB Local Oscillator Frequency	10.7 GHz dual and or quad output
System Bandwidth	950 to 2050 MHz
Cascaded I.F. Amplifiers	2 normally (never to exceed 3 in total, including line pre-amplifier and launch amplifier)
Cascaded I.F. Taps	3 normally (never to exceed 4)

4.2 OUTLET LEVELS: I.F. SATELLITE

Minimum	60dBuV
Nominal	65dBuV
Maximum	75dBuV
Minimum Carrier to Noise Ratio	15 dB / MER 13

4.3 SATELLITE LNB RECEIVE LEVELS

LNB O/P typically	75 to 85dBuV
-------------------	--------------

4.4 RF MUTUAL ISOLATION BETWEEN OUTLETS:

The RF mutual isolation between any system outlets, either within or between premises, shall not be less than 20dB within the band 950 – 2050 MHz. (Refer to AS/NZS 1367-2007)

4.4.1 SATELLITE I.F. AMPLIFIER LEVELS

Input (nominal) 75dBuV \pm 5Db.

The nominal input level may vary due to system design constraints. It is important to adjust the amplifiers input attenuator so that the maximum output levels shown below are not exceeded. A 4dB-reserve gain is recommended for all amplifiers, and this should be taken into consideration when designing a system. A recommended maximum MOL on any system is no greater than 110dB. De rating must be taken into consideration when designing multi channel systems.

5 NORMAL MATV R.F. SYSTEM PARAMETERS

5.1 GENERAL

System Bandwidth	5 to 864 MHz
Cascaded RF Amplifiers	2 normally (never to exceed 3 in total, including line pre-amplifier and launch amplifier)
Cascaded RF Taps	3 normally (never to exceed 4)

5.2 OUTLET LEVELS: RF MATV

Minimum	60dBuV Analogue 50dBuV Digital
Nominal	70 dBuV Analogue 60dBuV Digital

Maximum 80 dBuV (77dBuV > 20 channels) 70dbuV Digital
Carrier to Noise ratio. The minimum C.N.R. of any AUSTAR TV channel is 44 dB for an equivalent noise bandwidth of 5 MHz at any outlet.
(Refer to AS/NZS1367-2000)

5.3 RF MUTUAL ISOLATION BETWEEN OUTLETS

The RF mutual isolation between any system outlets, either within or between premises, shall not be less than 30dB within the band 5 – 862 MHz., (Refer to AS/NZS 1367-2000 Appendix D for test method)

5.4 AMPLIFIER MAXIMUM OUTPUT LEVEL AND DE-RATING

All amplifiers are rated with a maximum output level (MOL) for a given number of channels. An older specification for an amplifiers MOL was referred to as DIN45004B. This specification states the MOL with a loading of 2 channels only. However most current commercial grade amplifiers quote the MOL based on the Cenelec 50083 standard with a 42 channel loading in line with European and Australian standards. Using this reference gives the network designer easier ability to allow for future program expansion. If an amplifier's MOL is specified to DIN45004B based on a 2 channel loading, then the designer will need to derate, or reduce the MOL based on approximately 3 dB reduction for each doubling of the number of channels, in accordance with the following de-rating table. Refer AS/NZ 1367;2007 table 4.1

NO. OF CHANNELS	2	3	4	6	8	10	12	16	20	24	36
M.O.L. LEVELREDUCTION IN DB FROM DIN 45004	-0	-2	-3	-5	-6	-7	-8	-9	-10	-11	-13

5.5 R.F. AMPLIFIER LEVELS

Input (nominal) 75dBuV \pm 5dB

The nominal input level may vary due to system design constraints. It is important to adjust the amplifiers input attenuator so that the maximum output levels shown below are not exceeded. A 4dB-reserve gain is recommended for all amplifiers, and this should be taken into consideration when designing a system. A recommended maximum MOL in MATV designs is 110 dB.

5.6 PASSIVE DEVICE LOSSES

As per manufacturer's instruction sheets and approved parts list.

6 SYSTEM OUTLET LEVELS AND PERFORMANCE

The following outlines the recommended signal level and level spread at any given outlet.

6.1 DIGITAL VIDEO BROADCAST SATELLITE (DVB-S) TELEVISION CHANNELS

The maximum transponder carrier level difference measured at the outlet between any DVB-S television channels in the range 950-2050 MHz shall not exceed 6 dB.

I.F. satellite levels for QPSK transmissions must be between 58 and 75 dBuV at all subscriber outlets within the system. (65dB optimum). Minimum I.F. Outlet Carrier to noise ratio is 13dBuV. Minimum cross-polarity must not be less than 2dB of the C/N Ratio.

6.2 ANALOGUE AND DIGITAL VIDEO BROADCAST TERRESTRIAL (DVB-T) TELEVISION CHANNELS

In the range 45 – 862 MHz the difference of any channel vision carrier, measured at any system outlet shall not be greater than 12 dBuV.

Within any 70 MHz band the difference of any analogue channel vision carrier, measured at any system outlet shall not be greater than 6 dBuV.

Between any adjacent analogue television channels, the maximum vision carrier level difference measured at any system outlet shall not be greater than 3 dBuV. Up to 20 channels, Analogue Free to Air and modulated channels between 46 MHz and 864 MHz must be between 60 dBuV and 80dBuV at all subscriber outlets within the system. (70dB optimum) For more than 20 channels, Analogue Free to Air and modulated channels between 46 MHz and 864 MHz must be between 60 dBuV and 77dBuV at all subscriber outlets within the system. (70dB optimum)

Up to 20 channels, Digital Free to Air channels between 46 MHz and 864 MHz must be between 54 and 74 dBuV at all subscriber outlets within the system.

For more than 20 channels, Digital Free to Air channels between 46 MHz and 864 MHz must be between 54 and 70 dBuV at all subscriber outlets within the system. Digital free to air post Viterbi Bit Error Rate (BER) at any outlet must be < 2.0 E-6.

Broadcast type	System	C/N	MER	BER	
		Minimum dB	Minimum dB	Pre-Viterbi	Post-Viterbi
DVB-T		28	25	<8E-3	<2E-6
DVB-S		13	12	<6E-4	<2E-7
DVB-C 64 QAM		35	30		

6.3 FM RADIO

In the range 88-108 MHz the minimum r.m.s carrier level measured at any outlet shall be 40 dBuV for mono sound and 50dBuV for stereo sound.

In the range 88-108 MHz the maximum r.m.s carrier level measured at any outlet shall be 67 dBuV for both mono and stereo sound.

Note: The maximum in-band signal level spread across all outlets should not exceed 12 dB.

7 MEASURING SATELTITE QPSK SIGNAL

AUSTAR has specified the use of average level detection meters for measuring Satellite IF signals. These meters average the signal level in a 27 MHz bandwidth and display levels typically 9 or 10 dB higher than a peak level meter.

The reason for the difference in levels is due to the type of modulation used for the Satellite signal. The QPSK modulation scheme results in the transmitted signal power being dispersed across the transmission bandwidth while the transmission carrier has been suppressed.

For this reason digital QPSK carriers measured with peak detect meters return incorrect results as they only measure the power contained in a 600 KHz bandwidth and not the cumulative energy contained in the full bandwidth.

To measure the Digital signal with a Spectrum analyser we must take into account the Resolution bandwidth and the Video bandwidth that will be used to conduct the measurement. These parameters set the bandwidth and frequency content the Spectrum analyser will use to measure the signal.

These should be set to 3 MHz and 300 MHz respectively. The signal under measurement should be stabilised using the max hold function on your analyser and peak level should be noted. To convert from peak to average level, add 9dB.

7.1 Characteristics of Ratio types measured in Digital systems (informative)

As a brief explanation of some commonly used ratios in DVB modulations that are defined in detail in ETSI TR 101 290, the following may be helpful as a guide:

- a. C/N – Carrier to Noise ratio is measured in RF domain and is equal to the Channel power / Noise power both being measured within the channel bandwidth.
- b. MER – Modulation Error Ratio is measured in the modulation constellation domain and is a measure of the corruption of the modulation by noise and distortion within the confines of the digital channel bandwidth
- c. S/N (or SNR) – Signal to Noise ratio is measured after demodulation (I & Q)

For ideal signals corrupted by Gaussian noise only the relationship between these measured ratios are:

For DVB-S & DVB-C: $C/N = MER = S/N$

For DVB-T: $(C/N) - 1 = MER = S/N$ (1 dB of channel power taken by pilot carriers in COFDM)

Note that MER can never be larger number than C/N. In reception environments that are only corrupted by thermal noise the MER should only be 0 dB (1 dB for DVB-T) to 2 dB less than C/N. Hence in Table 6.2 the MER is less than the C/N in recognition other interferers including IM and amplitude slopes.

Where the received signal is corruption by multipath, intermodulation, interference and impulse noise, the MER can be substantially less than the C/N. In DVB-T terrestrial systems where there may be SFN networks in use, the artificially generated echoes can produce larger differences between C/N and MER and in some cases that may have high C/N can give low MER and consequently low BER resulting in intermittent or no reception. To analyse such reception problems, a meter with an impulse response facility is required to allow both echo time interval and level to be displayed. The BER should always be measured before Viterbi FEC rather than after Viterbi FEC (or pre RS) as the after Viterbi BER will very quickly, within typically 3 dB of the C/N threshold, decrease to zero errors ($<1E-8$) whereas the pre-Viterbi BER will typically still remain measurable. The before Viterbi BER is sometimes referred to as raw BER.

There will also be a linkage between BER and MER that is whenever there is a so-called low MER there will be a high BER. Both MER and BER should be noted, as the relationship between them will generally depend upon the character and type of noise or interference that is combined with the signal. Such a relationship may also vary with the particular meter used for measurement.

As there are a number of different meters available for the measurement of such ratios, a guide to the accuracy of the meter can be gained by looking at the value of the C/N, MER and BER at the threshold of failure of the particular digital service. The importance of a quality Digital Meter cannot be underestimated and must be used in the AUSTAR MyStar installations.



8 CABLING STANDARDS AND PROCEDURES

8.1 SYSTEM PLAN AND DRAWINGS:

All dual polarity SMATV systems and Commercial Bulk Head end MATV systems being designed to support AUSTAR services must be forwarded in electronic form to AUSTAR for review and approval prior to installation and commissioning of the system. CAD or Excel / Word based freehand drawings must include details as outlined in the AUSTAR CAD Drawing Standard 2004:1. (Refer to Section 9 on page 25).

8.2 EXTERNAL CABLING

8.2.1 Segregation

Cables must be installed away from power cables and electric fittings, not closer than the minimum 50mm separation distance, as stipulated in AS3000. For a summary, refer to table below. For detailed Segregation distance of cables refer to Communications Cabling Handbook SAA HB29 2000.

Install Situation	Clearance Required
Near insulated electrical service	600mm
Near uninsulated electrical service cables	1200mm
Near light fittings	50mm

8.2.2 Equipment Specifications

All cable, connectors, barrels and terminators must conform with the technical specifications outlined later in this manual, and AUSTAR approved parts list.

8.2.3 External Duct Installation

All External ducts must be installed as close as possible to the outlet location at time of construction.

8.2.4 Approved Cables

All drop cables must be approved type RG6 Quad shield and all trunk cables should be a minimum RG11 Quad shield, especially where the signal attenuation differential becomes significant due to cable distance. e.g.: Signal attenuation differential between RG6 and RG11 @ 2050 MHz over 50 meters = 6 dB. For approved cables refer to the AUSTAR Approved Parts list.

8.2.5 Techniques

All techniques employed to run cables on the outside of buildings should be compliant to local and state regulations and must meet AUSTAR quality standards. Cable installations must meet the requirements of the Australian Communications Authority.

8.2.6 Conduit and Supports

All vertical cabling on the exterior of a building must be protected in UV stabilised conduit or ducting and attached to the building at intervals not exceeding 0.5m. The support and anchors should be sufficient to support the cables combined weight. All horizontal cabling on the exterior of a building shall be protected in UV stabilised conduit or ducting and attached to the building at regular intervals, not exceeding 0.5m.

All underground conduits shall be heavy-duty type identified as orange in colour, designed for in ground burial.

8.2.7 Sharp edges

All cabling that passes over a sharp edge must be adequately protected and supported to avoid damage to the cable. All cable bend radius must be kept within the manufacturer's specifications.

8.2.8 Cable housing

All exterior cabling, both vertical and horizontal, must be protected from possible physical damage by a moulding (aluminium, colour bond or UV stabilised and in a pleasing finish). Moulding colour should match as closely as possible the existing building colours.

8.2.9 Fixing

All exterior housings must be fixed at regular intervals of no more than 0.5m with weatherproof fixings.

8.2.10 Terminating tools

The correct compression tools must be used for the specific connectors.

8.2.11 Underground Cable Runs

All underground cable runs must use flooded (silicon infused) quad shield cable housed in high density orange conduit, and buried to a depth in accordance with AS/NZS1367-2000./AS3000 / SAA HB29 2000 handbook.

8.2.12 Catenary Cable Runs

Catenary cable run between buildings must conform to AS/NZS 1367:2000. Messenger cable should be used, or the cable affixed to a separate messenger cable at intervals of no less than 1 meter. Minimum height and maximum span restrictions must be adhered to. Aerial cables shall not be run above electrical services. Clearances above ground and between other aerial services are summarised in the following table:

Austar Coaxial Catenary cable:-	Install Situation	Clearance Required
Run as aerial distribution	over non-trafficable areas	2400mm
Run as aerial distribution	over trafficable areas	3700mm
Run as aerial distribution	over areas used by high vehicles	4900mm

8.2.13 Labelling of cables

All drop cables must be identified at each end using cable labels or slide-on labels. Unit number or outlet identification must be made at the riser or multiswitch end, and riser / floor and /or multiswitch identification should be marked at the customer termination end.

8.3 INTERNAL CABLING

8.3.1 Segregation

For Segregation distance of cables refer to Communications Cabling Handbook SAA HB29 2000

8.3.2 Equipment Specifications

All cable, connectors, barrels and terminators must conform to the technical specifications outlined later in this manual and AUSTAR approved parts list.

8.3.3 Approved cables

All drop cables must be approved type RG6 Quad shield and all trunk cables should be a minimum RG11 Quad shield, especially where the signal attenuation differential becomes significant due to cable distance. Eg: Signal attenuation differential between RG6 and RG11 @ 2050 MHz over 50 meters = 6 dB.

For approved cables refer to the AUSTAR Approved Parts list.

8.3.4 Cable selection

The cable gauge selection for trunk and lateral cables should be determined by the inherent cable attenuation @ 2050 MHz, and the DC resistance over distance, to ensure sufficient voltage is available to any line amplifiers, and that the input level into any trunk amplifier does not fall below 75 dBuV.

8.3.5 Support

All vertical cabling on the interior of a building must be bundled and attached to the building at regular intervals close enough together to support their combined weight. All horizontal cabling on the interior of a building must be bundled and attached to the building at regular intervals not exceeding 1 – 1.5m.

8.3.6 Sharp edges

All cabling which passes over a sharp edge must be adequately protected and supported to avoid damage to the cable. All cable bend radii must be kept within the manufacturer's specifications.

8.3.7 Cable housing

All exposed interior cabling, both vertical and horizontal, must be housed in plastic ducting / conduit, run under skirting boards or concealed in a wall cavity. All interior cabling that is installed through a concrete slab at the time of building construction must be housed in conduit. It is preferred that these conduits are run in star configuration from the central riser one to each outlet location.

8.3.8 Fixing

All interior housings must be fixed at regular intervals of no more than 1 – 1.5m with weatherproof fixings.

8.3.9 Terminating tools

The correct compression tools must be used for the specific connectors.

8.3.10 Labelling of cables

All drop cables must be identified at each end using cable labels or slide-on labels. Unit number or outlet identification must be made at the riser or multiswitch end, and riser / floor and /or multiswitch identification should be marked at the customer termination end.

8.4 THE MDU HEADEND

8.4.1 Lead in Cable

Dual dedicated lead in cables from the dish LNB to the first active or passive device must be installed; diplexers are **not** permitted on lead in cables. Selection of RG6 or RG11 should be based on the cable DC resistance and signal attenuation over the length involved. Generally the cable distance between the LNB and headend or launch amplifier or multiswitch should not exceed 50 meters using RG6, or 80 meters using RG-11. If these distances need to be exceeded, line amplifiers are required to be installed at the dish location in a weatherproof enclosure, and dc power inserters or LNB line powering amplifiers are required.

8.4.2 Amplifiers and Passives

All amplifiers and passives must conform to the technical specifications outlined in this manual and approved parts list. Both satellite I.F. and RF amplifiers should have a nominal input level of 70 -75 dB to maintain adequate carrier to noise ratio.

8.4.3 Housing

The headend must be installed in a common key lockable steel or UV stable plastic cabinet containing the launch amplifier and the splitter / tap network or multiswitch. The cabinet, if constructed of steel, should be earthed in accordance with local regulations.

8.4.4 Ventilation

Ventilation must be installed into cabinets where necessary to avoid ambient temperatures exceeding the operating range of active equipment.

8.4.5 Mounting

The headend must be mounted in a location taking into consideration power availability, ambient temperature, and security. Lockable riser cupboards or lockable wall mounted enclosures are the preferred option.

Where possible launch amplifier headends should not be located in the roof space.

8.4.6 Cable entry

Any exterior multi-cable entry point to the headend area (eg if headend is in a room) must be housed in weatherproof aluminium, colourbond or UV stable plastic housing. Cables should be housed in conduit all the way into the headend cabinet. Penetration into the cabinet must be via appropriate glands.

8.4.7 Power

A double GPO must be installed in accordance with relevant Australian Standards within the cabinet and connected to universal house power.

8.4.8 Earthing

Mains powered Multiswitches, Amplifiers and passive devices must be earthed in compliance with AS/NZS 1367:2000.

8.5 8.5 SUB-DISTRIBUTION

8.5.1 Amplifiers, Multiswitches and Passives

All amplifiers, multiswitches and passives must conform to the technical specifications outlined in this manual and the AUSTAR approved parts list.

End of line power passing cascaded multiswitches MUST have capacitive 75 ohm terminators fitted to the through-ports. Resistive 75 ohm terminators MUST NOT be used on power passing through-ports.

No more than 3 cascaded taps should be used in any MATV or SMATV system design.

Multiple trunks split off from the headend should be used to achieve the required number of outlets.

Splitters must never be used as the last end of line passive device. Only 75 ohm terminated taps or multiswitches should be used as end of line termination. Mains powered Multiswitches must be earthed in accordance with AS/NZS 1367:2000. Remote line powered multiswitches do not require earthing.

8.5.2 Housing

All sub-distribution points (located externally to a communications / electrical riser or similar) must comprise of a common keyed lockable steel or UV stable plastic cabinet containing the required multiswitch / amplifiers or split / tap network.

Sub distribution housings located within risers must be constructed of plastic using fixing screws on the lid.

8.5.3 Mounting

The sub-distribution point must be mounted in a location taking into consideration ambient temperature, height access by contractors not to exceed 3 storeys and security. It must be located in a position easily accessible from common property.

8.5.4 Cable entry

If the sub-distribution point is located externally to a riser cupboard, cables must be housed within conduit all the way into the cabinet. Penetration into the cabinet must be via appropriate glands.

8.5.5 Power

240V GPOs are to be supplied to power any amplifiers contained within sub-distribution points. The responsibility of the 240V GPO must be documented on the B/C quote and AUSTAR Site Survey and System Design.

8.6 SYSTEM OUTLETS

8.6.1 Equipment Specifications

All F type connectors, barrels and terminators must conform to the technical specifications outlined in this manual and must be approved as per the AUSTAR approved parts list.

8.6.2 Outlet plates

All outlet plates must conform to the technical specifications outlined in this manual or approved parts list. (Refer Section 1 Passive Equipment, page 6)

For termination from 2 input I.F. multiswitch, a separate plate to the free to air outlet should be installed unless otherwise specified.

For new installations using 3 input multiswitches, an approved wall plate with onboard diplexer should be installed.

8.7 CABLE ATTENUATION AND EQUALISATION

Before any system is designed, it is important to understand the requirements of the design and the losses incurred. This is where choosing the correct cable to match the system losses come into effect.

8.7.1 ATTENUATION AND EQUALISATION

All satellite I.F system designs should be calculated using the following attenuation figures.

RG6: 0.22 dB loss per metre at 950 MHz, and, 0.32 dB loss per metre at 2050 MHz.

RG11: 0.14 dB loss per metre at 950 MHz, and, 0.21 dB loss per metre at 2050 MHz.

Where integrated FTA / Satellite SMATV systems are to be installed, the FTA system losses must also be calculated using the following attenuation figures.

RG6: 0.05 dB loss per metre at 55 MHz, and, 0.20 dB loss per metre at 862 MHz.

RG11: 0.03 dB loss per metre at 55 MHz, and, 0.14 dB loss per metre at 862 MHz

$$R(f_1) = R(f_2) \times \sqrt{\frac{f_1}{f_2}}$$

R (f1) = Cable Loss at frequency f1

R (f2) = Cable Loss at frequency f2

F1 = frequency

F2 = frequency

8.7.2 EQUALISATION

It is known that the attenuation of a coaxial cable is greater at higher frequencies than at lower frequencies as shown in Figure 3 below.

Reference:

The loss at the lower frequency channels will be much less than at the higher frequencies, and this means that it is not possible to compensate for the loss by simply introducing an amplifier of a certain gain. Ideally, the design needs to provide equal amounts of signal at both high and low frequency extremes at the outlet, and in order to achieve this, the amplifier and system should correct the cable losses at each particular frequency, a process called equalisation.

From B of Figure 3, it can be seen that the loss at channel 20 might be shown for a typical length of cable at 15dB and we would see that the loss for that same length of cable at channel 73 would be 20 dB. We can see that the loss in the cable varies with frequency logarithmically. The attenuation varies approximately as the square root of the ratio of the frequencies involved. In the instance of channel 20 and channel 73, the loss would be proportionate to the square root of 471.25 MHz (channel 20) divided by 847.25 MHz. MHz (channel 68) that would be equal to ¾ approximately. In other words, the attenuation at

channel 20 is $\frac{3}{4}$ that at channel 73. If plotted on log graph paper the curve of cable attenuation versus frequency can be shown as a straight line (see C of figure 3). Ideally the amplifier should exactly compensate for the loss of the cable. If we therefore draw a line from +15 dB at channel 21 to +20 dB at channel 68 and we can show that this amplifier gain will then exactly compensate or be opposite to the loss in the cable. It can be seen from the curve that this amplifier gain is sloped, i.e.: the gain increases with frequency. It is the sloped gain type of amplifier, i.e.: an amplifier with built-in equalisation that can compensate for the slope in the cable attenuation. Most RF and IF amplifiers have built-in equalisation, or optional plug-in equalisers.

Should a flat gain amplifier be used, i.e.: equal gain at all frequencies, it may be necessary to provide external equalisation to adjust the result of the un-equalised amplifier to the required slope that is equal and opposite to that of the cable. The upper line of the shaded area in C of figure 3 shows the gain of the flat amplifier. In order to match this curve to the cable losses, an equaliser is used to attenuate the low-end frequencies and effectively crop the shaded area shown in C of figure 3. This has the net effect of making the amplifier output equal and opposite to the cable loss.

However, the preferred option is to use amplifiers with on-board equalisation.

Note: The maximum in-band signal level spread across all outlets must not exceed 12 dB.

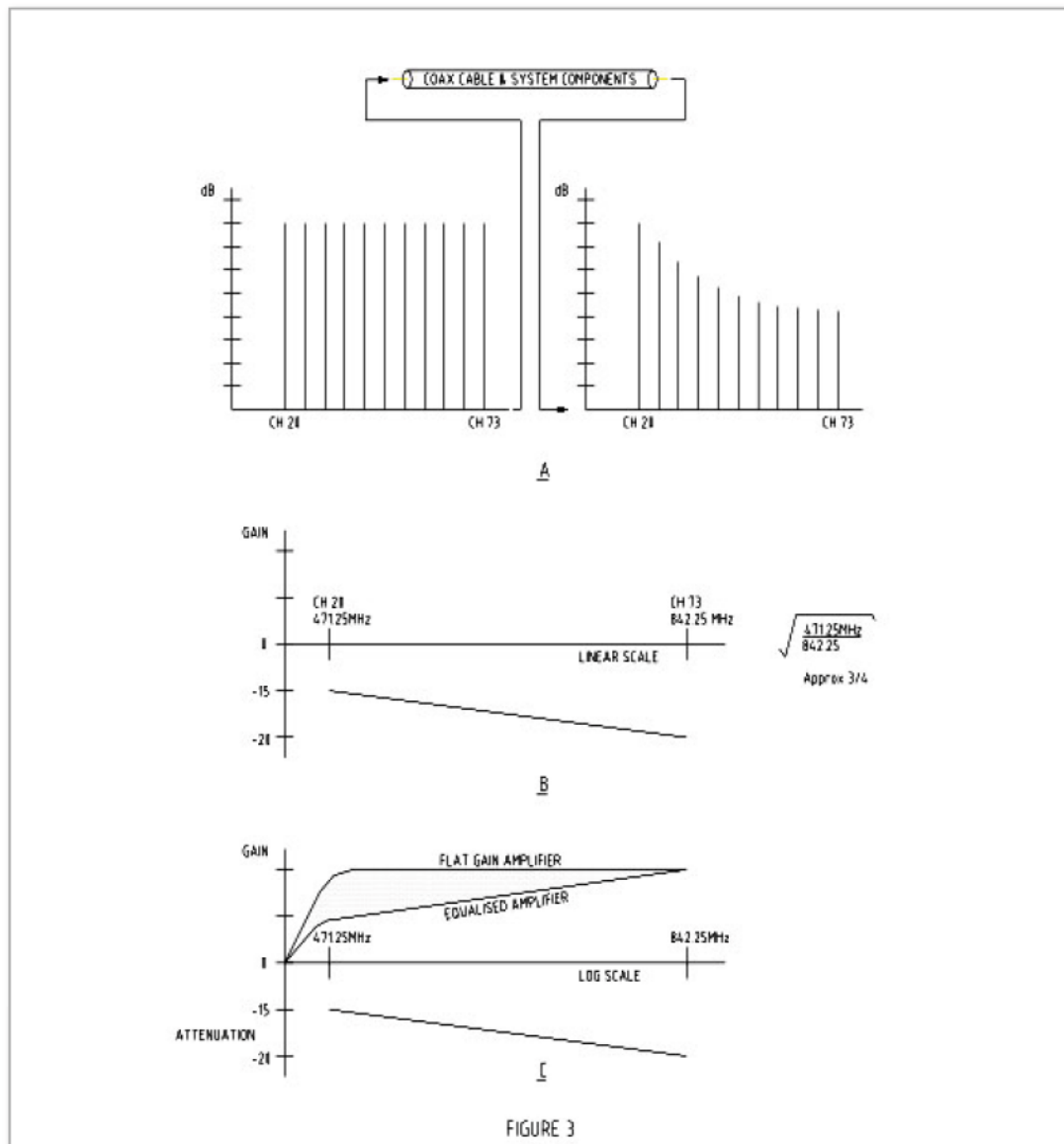
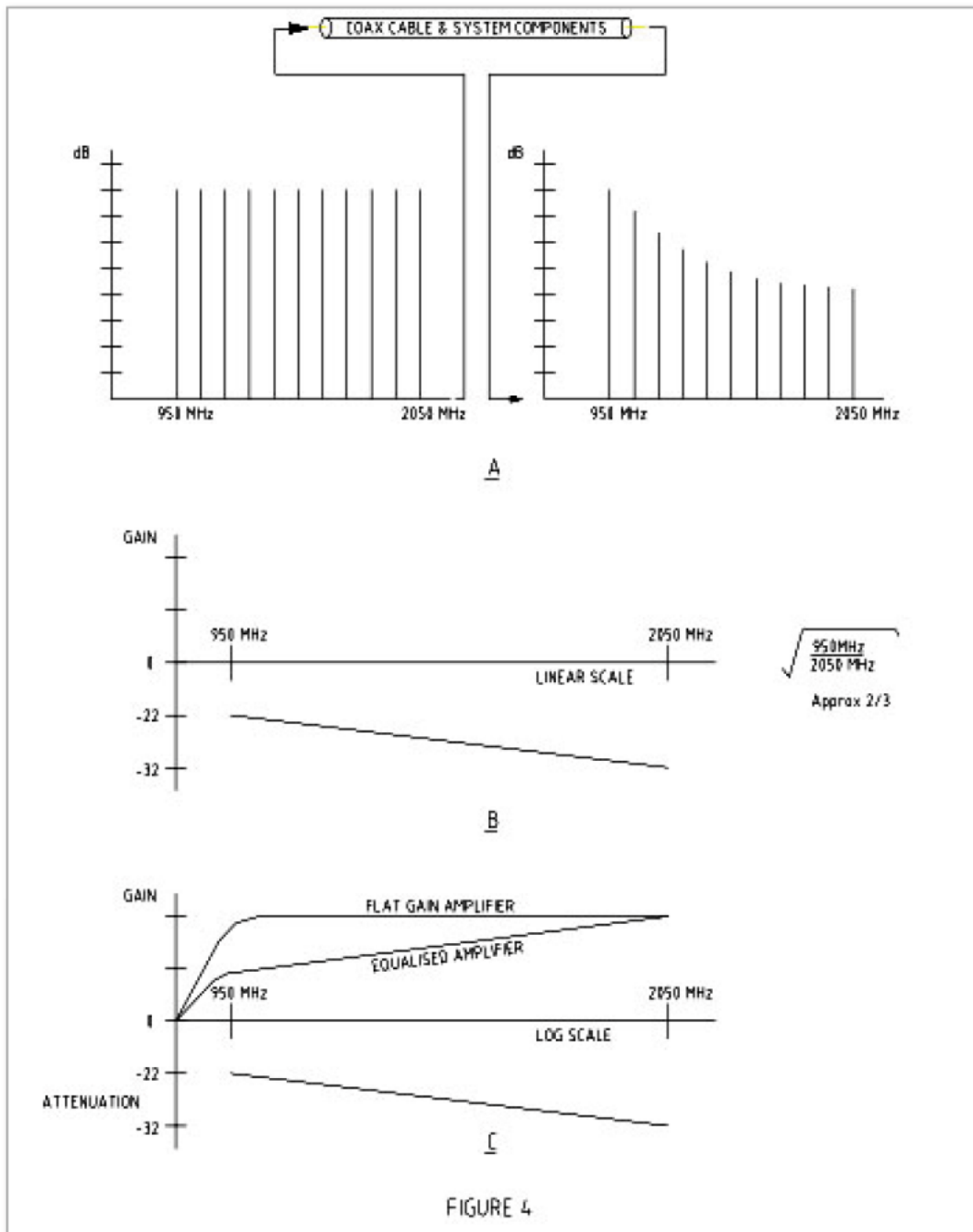

Figure 4 outlines the typical cable losses of a 100-metre length of RG6 at 950 MHz – 2050 MHz, you will note that an amplifier with 10dB slope is required to get a linear output.



9 AUSTAR CAD DRAWING STANDARD

9.1 INTRODUCTION

AUSTAR Field Operations requires a minimum standard of detail and signal level calculation in all system design drawings submitted, as this detail assists both the contractor and AUSTAR technical staff in rapid assessment and approval or revision of surveys for on forwarding to the customer. Site survey and as-built drawings submitted without the following detail will be returned to the contractor for completion and re-submission.

Up to Four (4) building site drawings are generally required with MDU and AUSTAR for Business site surveys and Commission reports, depending on the scope of work involved. Drawing diagrams can be combined where clarity of detail is maintained.

9.1.1 Building outline:

This is a basic outline of the building layout showing the complex layout, external pedestal locations, building or basic floor layout, dish and headend location, direction of North, distance between buildings and approximate building dimensions. Indicative unit / room numbering must be included to enable identification of sample room level readings with the building layout, especially end of line. Digital photographs are recommended to help illustrate the proposed dish location in the site survey and commission report.

9.1.2 Existing headend and distribution system:

For AUSTAR for Business surveys, a system layout approximation based on findings during the on-site visit is mandatory unless the existing system will not be used in any way for AUSTAR or FTA distribution.

A completely new re-cabling of the site should be clearly justified and stated in the Scope of Works. Any system uncertainties due to limited access while on site or untraceable cable and conduit runs should be mentioned within the detailed Scope of Works. (Building outline and Existing distribution approximation can be combined into the one drawing if preferred). For MDU site surveys, the existing system drawing is only required if any part of it will be used in the proposed design.

9.1.3 Proposed headend and distribution system.

A proposed satellite I.F. (and FTA if integrated using 3 input multiswitches) or Bulk headend and distribution system from dish to wall plate including a key or legend, specification text, active and passive device detail, calculated estimated signal path levels and expected subscriber wallplate results is mandatory for both MDU and AUSTAR For Business site surveys. Location of proposed conduit runs and entry points should be included.

9.1.4 As-Built headend and distribution system.

This is generally an updated version of the proposed system drawing, but with actual measured, not planned signal measurements, component values and any revisions to the system layout. This drawing reflects the detailed system results recorded in the commission report.

Refer to drawing examples later in this section.

9.2 DRAWING FORMATS

CAD (Computer Aided Design) preferred drawing formats are software formats including AutoCad, AutoCad LT, AutoSketch, Visio, etc. However, manually drawn diagrams using Excel or Word Drawing Tool or other similar Microsoft drawing systems are acceptable provided the required detail is not compromised.

(Hardcopy sketches and faxed drawings should be avoided where possible, but if these are to be submitted for consideration, they should be scanned first for electronic submission.)

Regardless of the drawing format used, the proposed design and as-built drawing needs to include the technical detail as outlined in the following section:-

9.3 REQUIRED SMATV SYSTEM DRAWING DETAIL:

9.3.1 Plan Identification

Must include:

1. MDU Site Identification Number, building name (if applicable) and address
2. Date of plan drawing and author

9.3.2 Specification Text, legend or Data section

The specification data section within the CAD diagram should indicate the following information:

- Amplifier minimum and maximum outlet levels.
- Cable type to be stated for all trunk and laterals / drops
- Drop cable Longest Home Run (stated as L.H.R. = x meters) and Shortest Home Run (stated as S.H.R. = x meters) between multiswitch and wallplate location, or last tap and wallplate location for Bulk Headend MATV builds.
- Satellite dish make, size and mount detail
- Wallplate minimum and maximum outlet level spread across 950 MHz and 2050 MHz, and include 50 MHz and 860 MHz if integrated with a FTA and / or bulk headend system. (Note: The maximum in-band signal level spread across all outlets should not exceed 12 dB.)
- Wallplate design: integral diplexer or standard F type barrel connector.
- Key or Legend explaining any colour codes used or non-standard symbols.

9.3.3 Cable Distances

All significant trunk and lead-in cable lengths as follows:

- Dish to line amplifier, and/or
- Dish to launch amplifier or multiswitch
- Distance from launch amplifier to any line extension amplifier
- Tap / splitter to multiswitch.
- Tap to wallplate for Bulk Headend MATV systems, stated in the legend or specification as S.H.R. [Shortest Home Run] and L.H.R. [Longest Home Run].
- Multiswitch to wallplate, stated in the legend or specification as S.H.R. [Shortest Home Run] and L.H.R. [Longest Home Run].

'Significant cable lengths' apply in excess of 5 meters.

To simplify drawing complexity, a 5 meter 'Significant Cable Length' threshold can be nominated within the Legend or Specification section. Eg: 'Only significant cable lengths over 5 meters will be detailed' or 'All non-specified cable lengths between components are less than 5 meters'.

9.3.4 Underground and Catenary cable runs

All underground or overhead catenary cable runs must be identified, together with cable type, (flooded if underground), length and conduit size and type.

9.3.5 Power Insertion Devices

Power insertion devices must be detailed in the drawings, and are required to power the LNB in cases where a launch amplifier is installed that does not provide line powering to the LNB, or where line amplifiers are installed at the dish location to overcome losses due to long cable runs, typically 50 meters for RG6 and 80 meters for RG11. Power insertion devices must be detailed with their respective output voltages.

9.3.6 Amplifiers

All amplifiers must show make and model, indicative input and output levels at lowest and highest frequencies within each specific bandwidth: i.e. FTA (50 MHz - 860 MHz) and Satellite I.F. (950 MHz – 2050 MHz).

9.3.7 Splitters, Taps and Multiswitches

All passive devices must be marked with a symbol reference or legend showing their type, location and size and indicate terminators on through legs and unused ports where applicable. All tap values must be indicated. Indicative input and output levels of FTA and I.F. at multiswitches must be included. Location of multiswitches must be included.

9.3.8 Outlet Plates

Example outlet plate levels and level spans across FTA and I.F. bandwidths must be shown at a minimum and maximum distance from the launch amplifier, if not specified in the Specification / Data Text section on the drawing. (See Specification Text section above). Outlet plate design should be stated as a standard F barrel or integrated diplexer type if not already specified in Specification Text section.

9.3.9 Headend and sub-distribution points

These areas should be indicated with a broken line. The presence of a broken line also indicates the equipment located at that point. These areas must be labelled with their location, eg; 'riser cupboard level 6'. On more complex drawings these areas may be drawn separately in an enlarged format. Commercial Bulk headends must state the AUSTAR RF channel selection, local Digital and Analogue FTA channels in the CAD drawing legend or Specification Key section.

9.3.10 Pedestals

All pedestals must be above ground type, and all pedestal locations must be marked on the system plan Drawing symbols and examples. The prime contractor should use the drawing symbols prescribed by AUSTAR or as approved in AS/NZS 1367:2000.

9.3.11 Conduit locations and entry points

Wherever possible, the proposed conduit runs and building entry locations should be indicated in the proposed distribution drawing or on the building outline drawing.

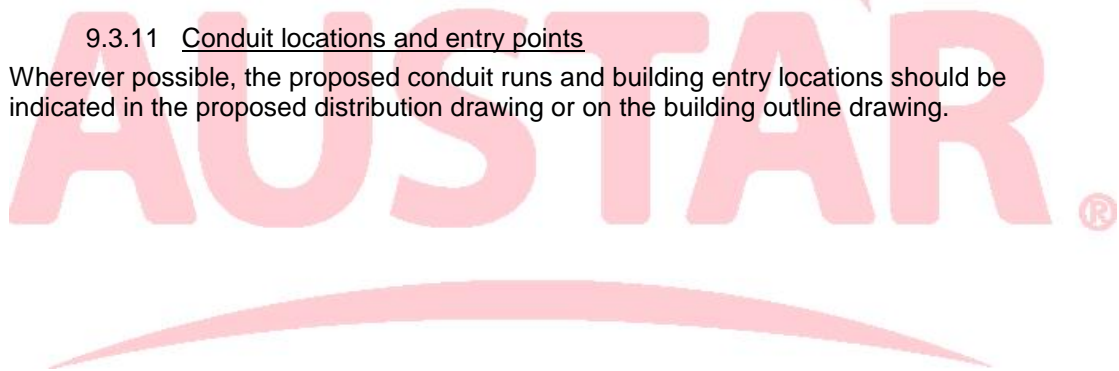

9.4 DRAFTING SYMBOLS.

SYMBOL	DESCRIPTION	SYMBOL	DESCRIPTION	SYMBOL	DESCRIPTION	SYMBOL	DESCRIPTION
	PROCESSOR		3 INPUT 4W MULTISWITCH END OF LINE ACTIVE FTA & SAT		2 WAY CUSTOMER TAP		VARIABLE EQUALISER
	MODULATOR		3 INPUT 4W MULTISWITCH END OF LINE ACTIVE SAT PASSIVE FTA		4 WAY CUSTOMER TAP		IN LINE EQUALISER
	CHANNEL AMPLIFIER		3 INPUT 8W MULTISWITCH END OF LINE ACTIVE FTA & SAT		6 WAY CUSTOMER TAP		TERMINATOR
	OPTICAL TRANSMITTER		2 INPUT 8W MULTISWITCH END OF LINE ACTIVE SAT		2 WAY CUSTOMER TAP SELF TERMINATING		DC BLOCK
	OPTICAL RECEIVER		3 INPUT 4W MULTISWITCH END OF LINE MANS POWERED ACTIVE FTA & SAT		4 WAY CUSTOMER TAP SELF TERMINATING		POWER SUPPLY
	OPTICAL SPLICE		3 INPUT 8W MULTISWITCH END OF LINE MANS POWERED ACTIVE FTA & SAT		6 WAY CUSTOMER TAP SELF TERMINATING		POWER INSERTER
	OPTICAL SPLITTER		3 INPUT 4W MULTISWITCH CASCADABLE PASSIVE FTA & SAT		2 WAY SPLITTER		AMPLIFIER FORWARD PATH ONLY
	DIPLEXER		3 INPUT 8W MULTISWITCH CASCADABLE PASSIVE FTA & SAT		3 WAY SPLITTER 1 HIGH/2 EQUAL O/P's HIGH O/P DENOTED		AMPLIFIER WITH REV PATH MODULE
	LOW PASS FILTER		2 INPUT 12W MULTISWITCH END OF LINE ACTIVE SAT		3 WAY SPLITTER 3 EQUAL OUTPUTS		HEADEND
	HIGH PASS FILTER		2 INPUT 12W MULTISWITCH CASCADABLE ACTIVE SAT		4 WAY SPLITTER		CABLE SPLICE
	BAND PASS FILTER		5 INPUT 8W MULTISWITCH CASCADABLE PASSIVE FTA & SAT		DIRECTIONAL COUPLER		ELECTRICAL EARTH (EET)
	ATTENUATOR		3 INPUT 3 OUTPUT LAUNCH AMP LINE POWERED		3 INPUT / 3 OUTPUT MULTIMAP		UHF ANTENNA
	OUTLET		2 INPUT 2 OUTPUT FTA-SAT SPLIT BAND AMPLIFIER LINE POWERED		5 INPUT / 5 OUTPUT MULTIMAP		VHF / UHF ANTENNA
	INTEGRATED RECEIVER DECODER		3 INPUT 3 OUTPUT LAUNCH AMPLIFIER MANS POWERED		5 INPUT / 5 OUTPUT TWO WAY SPLITTER		VHF ANTENNA
	SATELLITE ANTENNA		3 INPUT 2 OUTPUT LAUNCH AMPLIFIER MANS POWERED		5 INPUT 5 OUTPUT LAUNCH AMPLIFIER MANS POWERED		SATELLITE ANTENNA

9.5 EXAMPLE OF BUILDING OUTLINE WITH EXISTING SYSTEM

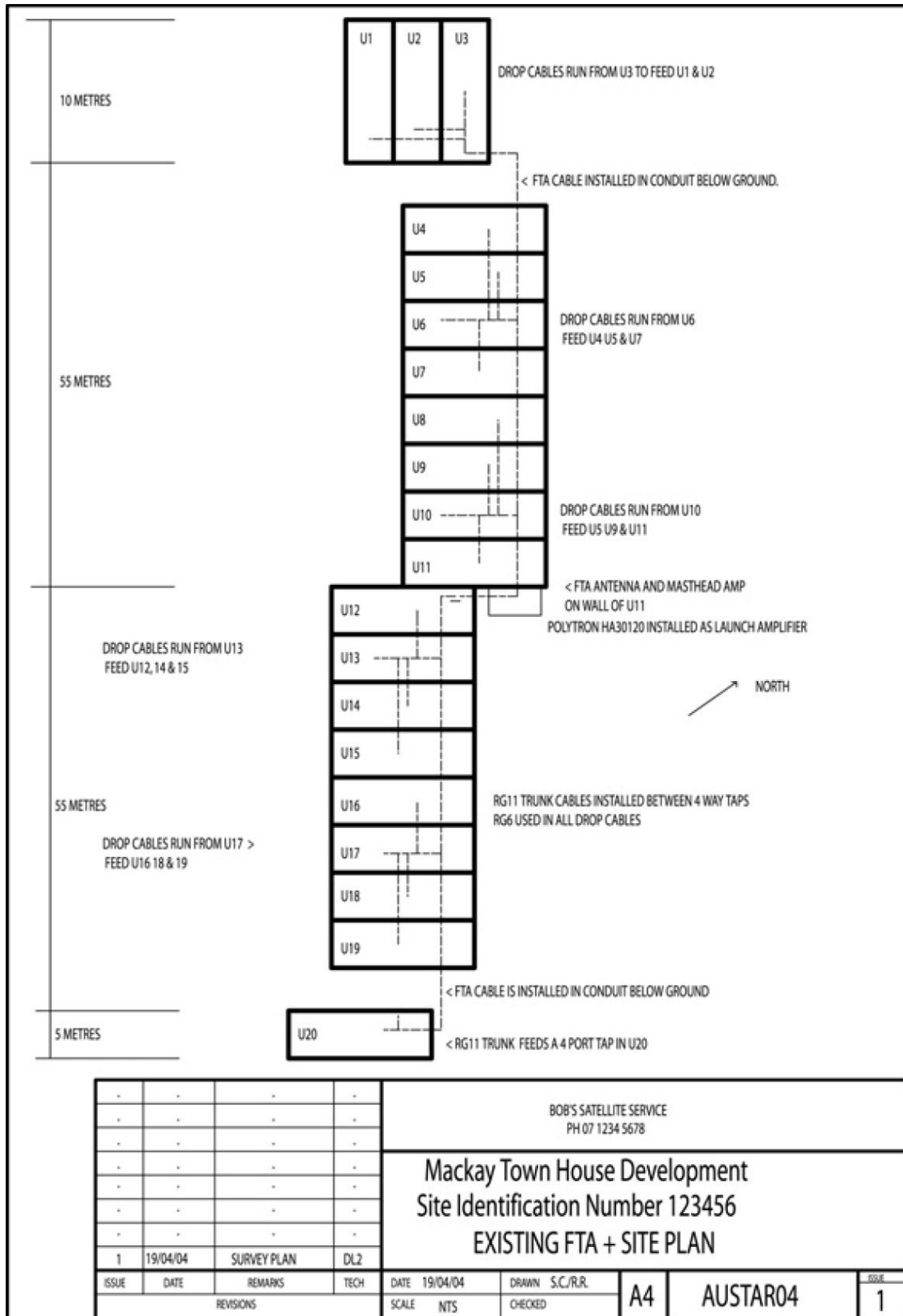

9.6 EXAMPLE OF BUILDING OUTLINE WITH PROPOSED SYSTEM

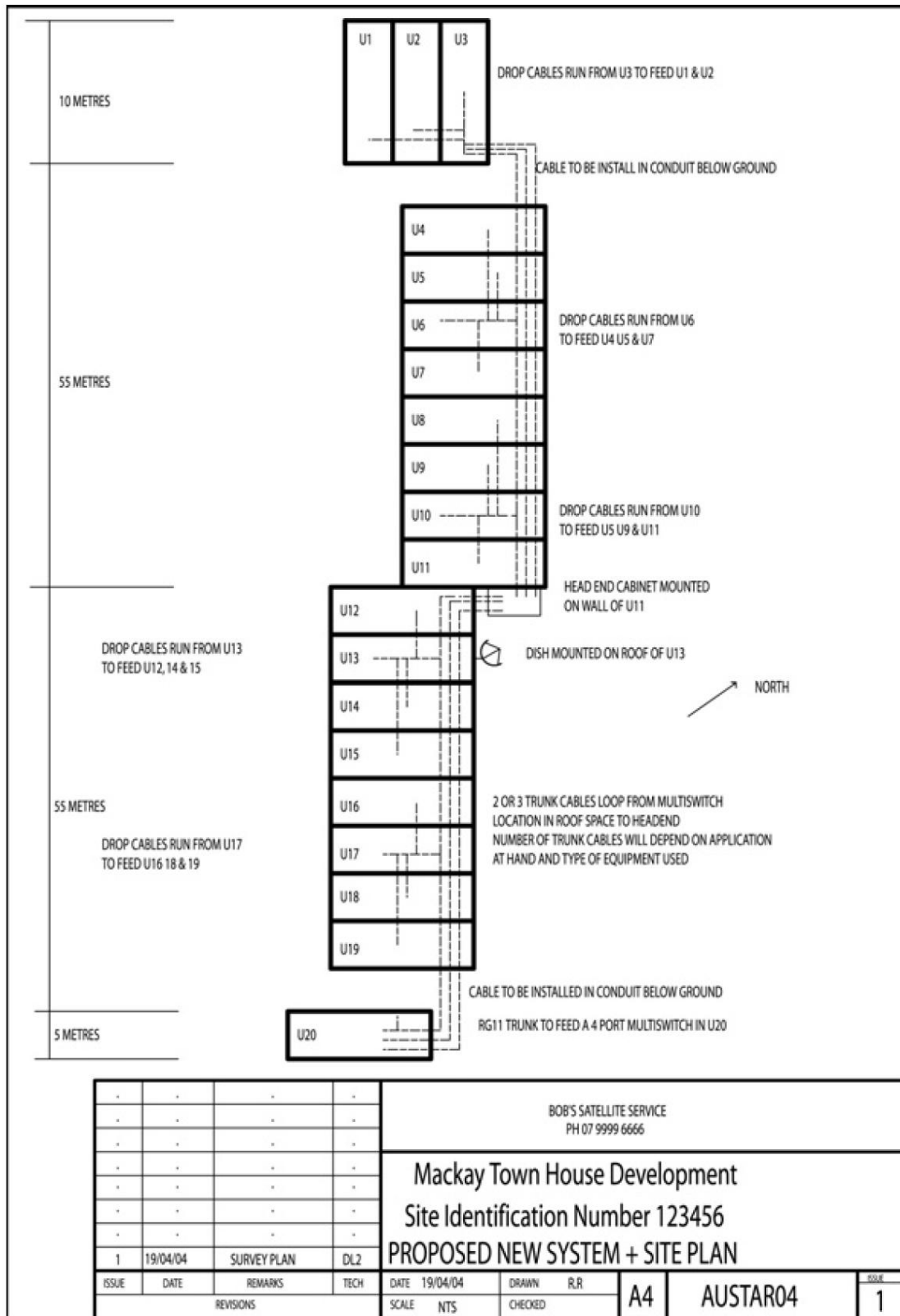

9.7 EXAMPLE OF PROPOSED MDU DESIGN DRAWING

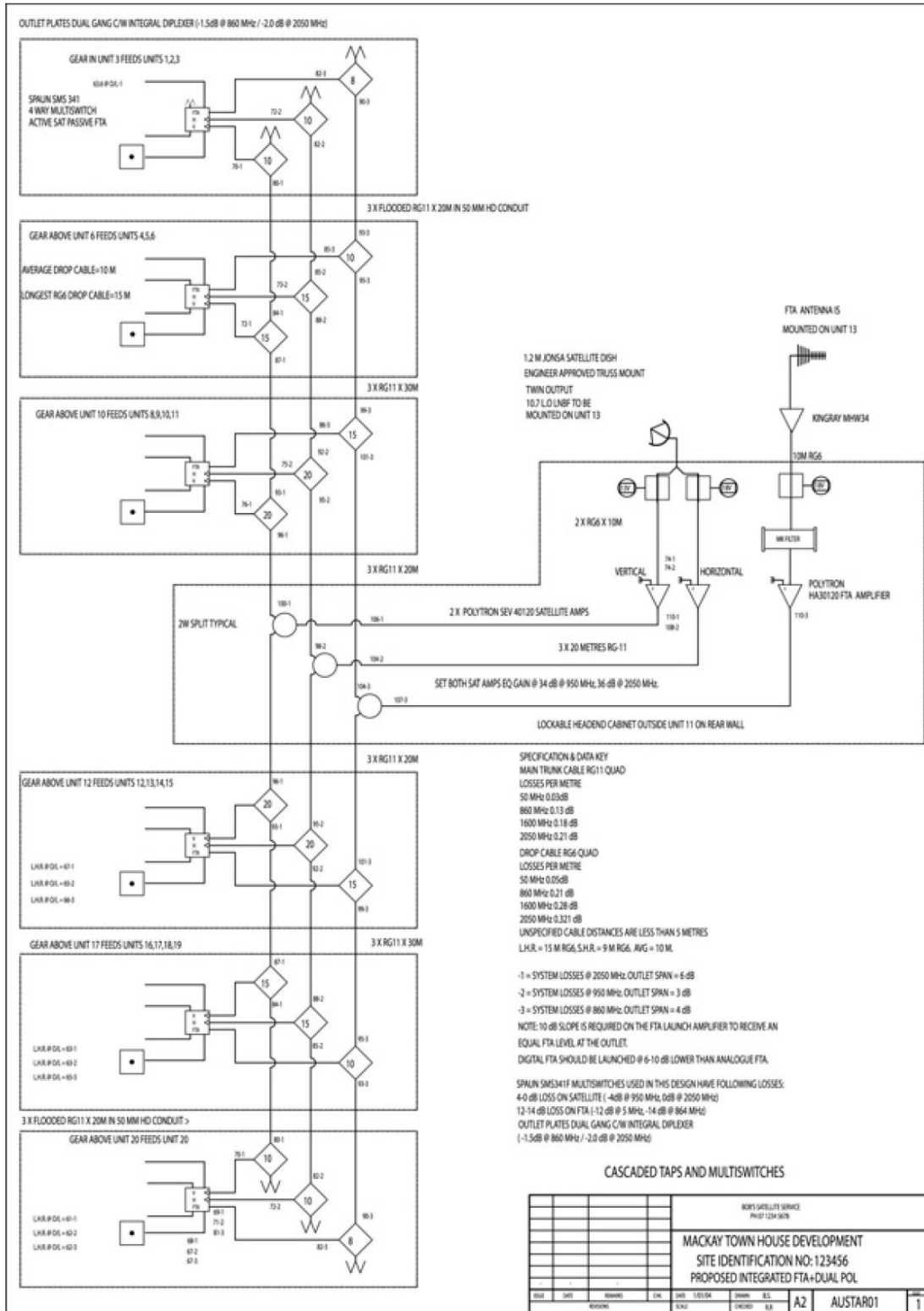

10 EARTHING OF A SYSTEM

10.1 EARTHING OVERVIEW

The System must be earthed in compliance with AS/NZS 1367:2000. (Refer to section 2 – Safety Requirements).

All Mains powered Multiswitches require earthing in accordance with AS/NZS 1367:2000.

Line powered Multiswitches do not require earthing.

Equipotential bonding is used to ensure that no hazardous voltages are present on the outer conductors of a cable or any metallic component within the network.

A licensed electrician must carry out connections within the electrical switchboard; otherwise a suitably qualified person can carry out the connection for protective earthing externally to the switchboard.

Connection for protective earth can be made external to the switchboard providing that the earthing conductor(s) are not cut or modified in any way and that the electrical integrity is not impaired. Insulation that is removed from the earth cable for purpose of making connection should be reinstated.

In multistorey premises connection of a bonding conductor must only be connected to the earthing conductor on the vertical rise between floor and the branch –off for the switchboard or distribution board.

Further information on CET's can be obtained from AS/NZS3000, (earthing conductors), and AS/ACIF S009:2001.

The CET must not be connected via the bonding conductor to the earth electrode.

The cable used between the switchboard and CET must be a minimum of 6mm².

The cable used between the earthing conductor and the CET must be a minimum of 6mm².

The cable used to bond the powered multiswitch to the CET must be a minimum of 2.5mm².

(This will change to 6mm² when a surge suppression device is placed in the line).

10.2 PREFERRED METHODS FOR CET AND BONDING CONDUCTOR CONNECTION

The following diagram outlines 2 preferred methods for connection of a CET and bonding conductor.

Option for Equipotential Bonding in small or large Multiple Premises Installation

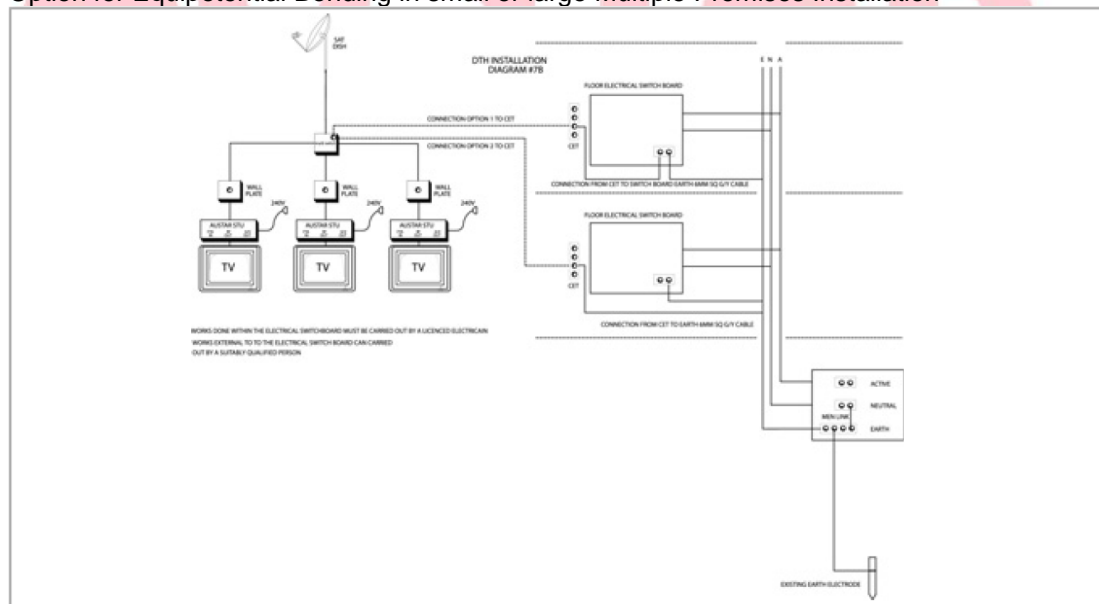

Option for Equipotential Bonding in a Single Premises Installation

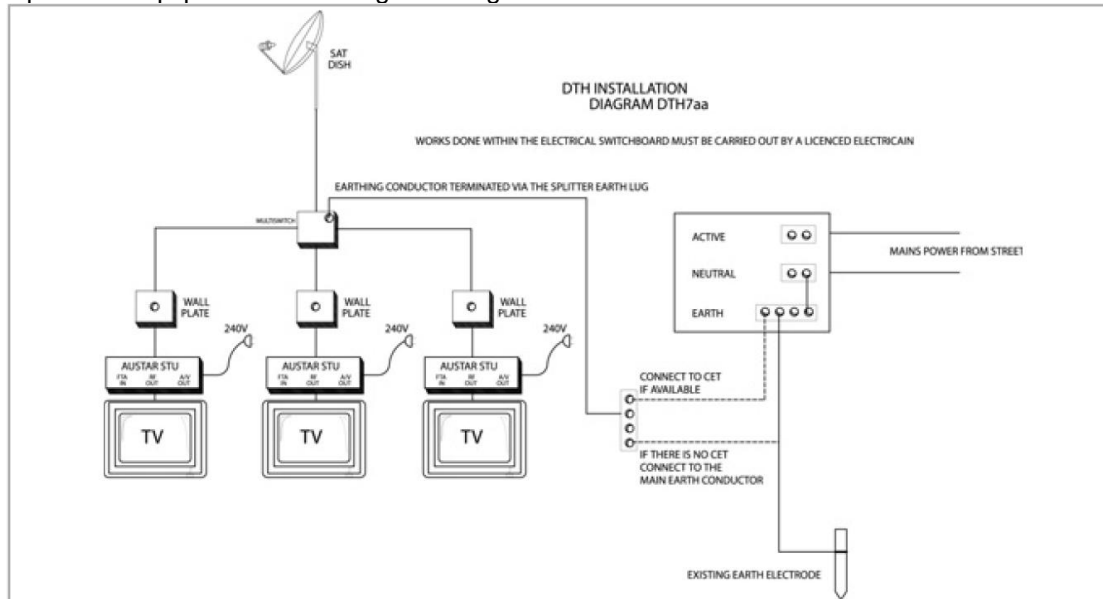

10.3 CONNECTION OF THE BONDING CONDUCTOR TO THE EARTHING CONDUCTOR

10.3.1 Connection of conductors

The connection of bonding and earthing conductors should be carried out by the use of a line tap. The insulation should be removed from the earthing conductor no more than necessary, and should be reinstated once the connection is made. Connections that are subject to the weather should be wrapped in amalgam tape before the earthing tape is applied. This process is shown below.

Connection of conductors via a line tap

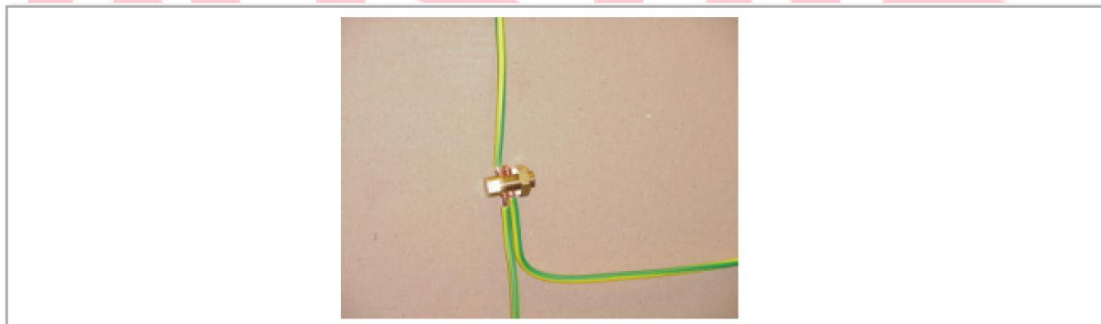

10.3.2 Installation of Amalgam Tape

Connection Wrapped in amalgam tape to protect against the weather.

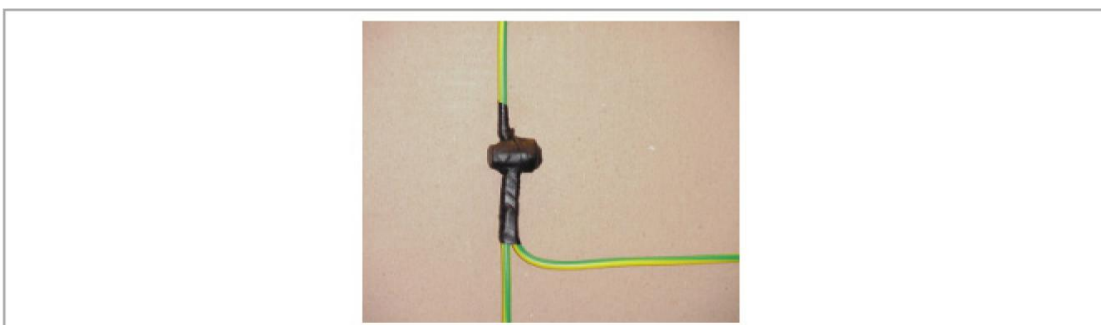

10.3.3 Connection with Insulation Reinstated

Connection with insulation reinstated via the use of electrical tape

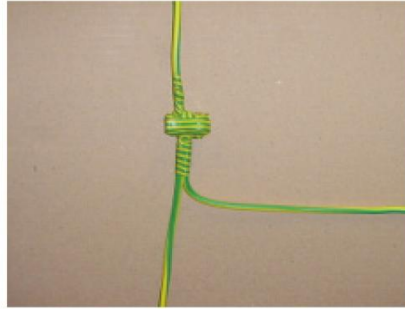

10.3.4 Simplified Version of a Bonding System

Bonding of the system is achieved via the following method.

- Multiswitch is connected to the CET via a 2.5mm² yellow green earth wire.
- The connection between the CET and the Earthing Conductor via a 6mm² yellow green earth wire.
- Typically the existing earth conduct is a minimum of 6mm².

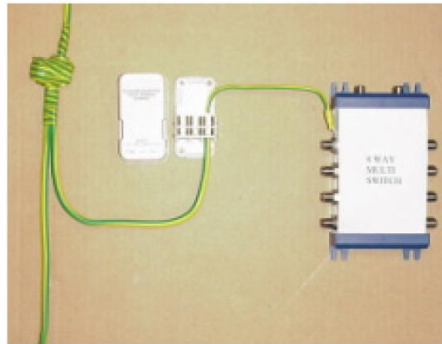

11 FIBRE OPTICAL CONNECTORS

Optical Connectors for use on MRE fibre backbones and large HFC cable networks. The following picture shows a typical ST type connector that can be spliced onto a fibre cable.

11.1 ST*/PC FIBRE OPTICAL CONNECTORS

The following picture shows a typical SCAPC type connector that can be spliced onto a fibre cable.

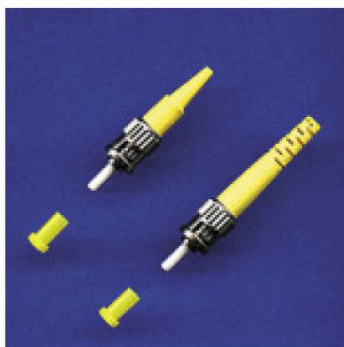

11.2 SC/APC DUPLEX FIBRE OPTICAL CONNECTORS SINGLE MODE

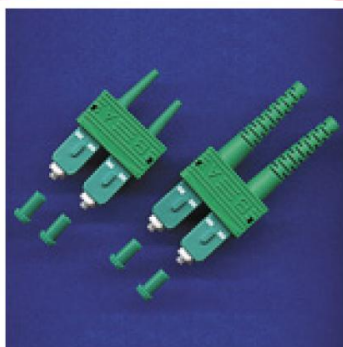

11.3 INTER CONNECTING LEADS

For inter connecting leads between devices pre terminated leads can be ordered from your supplier.

11.4 FOBOT

All spliced connections should connect to an FOBOT (fibre optic break out tray), this will take the load of the cable minimising the chance of broken fibres. The FOBOT has a compartment for housing pigtails resulting in a neat maintenance free installation.

11.5 CABLE TYPES

Cables used within an Optical system must be single mode with a minimum of 4 Cores. This will allow for redundancy in the case that one of the fibres or splices are broken.

11.6 CABLE BENDING RADIUS

It is critical that all fibre cables are treated with care and the minimum-bending radius must not be exceeded.

11.7 PIG TAILS

All 4 cores of the fibre are to be spliced with the correct connector and connected to the FOBOT, this will allow for ease of connection if and when required in the future.

11.8 SITE SPECIFIC

This type of system is site specific and will require specialised installers due to the complexity of the fibre splicing and specialised test gear required measuring the optical transmission.

11.9 DRIVE LEVELS

Input and output levels should not exceed manufactures specifications. All RF signals remain the same as per AUSTAR's standard specification.

11.10 EQUIPMENT

For a list of approved Transmit and Receive products refer to the AUSTAR Approved Parts List.



11.11.1 Attention: Commissioning Detail

- Commissioning documentation detail is available via AUSTAR MDU department via tek@austar.com.au
- Digital photographs of the Headend layout along with the dish installation is required with the commissioning documentation
- Submitting the Commissioning Reports must be sent to, tek@austar.com.au
- AUSTAR Approved Parts List is available via tek@austar.com.au

